

FRONT VIEW

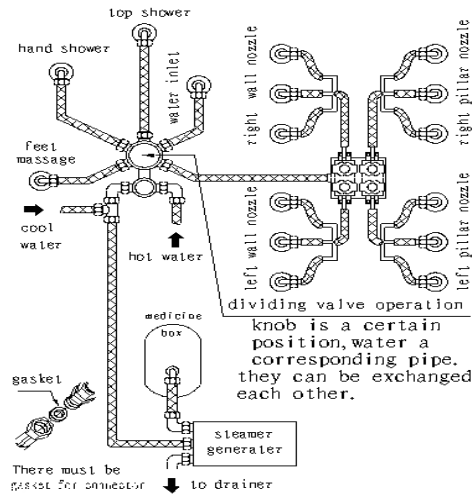

BACK SIDE WATER CONNECTION WAY

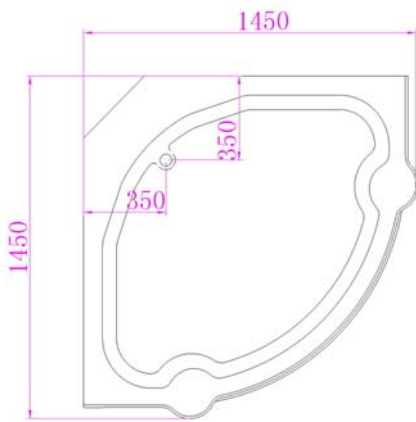

SHOWER TRAY VIEW

Gallon per Minute

Drain Water	8.98 US gal.	34 Liters/min.
Tap Water In	3.18 US gal.	12 Liters/min.
Top Showerhead	3.18 US gal.	12 Liters/min.
Movable Hand Showerhead	3.18 US gal.	12 Liters/min.
Back-wall body Jets	16.1 US gal.	61.2 Liters/min.

Water Pressure is 0.4~0.6Mpa.

Technical Specifications

G248

Products Dimension

L1450 x D1450 x H2200mm  
(L57" x D57" x H86.6")

Products Weight

Box A: 120 KGS (264 lb)  
Box B: 46 KGS (101 lb)

Shipping Weight

Box A: 180 KGS (396 lb)  
Box B: 75 KGS (165 lb)

Package Dimension

Box A: 1980 x 850 x 870mm (78"x33"x34")  
Box B: 1440 x 1440 x 370mm (57"x57"x15")

Electrical Specifications

Steam Generator: 3000W/110V/60Hz/27.3Aamps

Number of Jets

12 body massage jets

Minimum Working Water Pressure

4.0 bar (57.14 psi)

Maximum Working Water Pressure

8.0 bar (114.29 psi)

Recommended Working Water Pressure

6.0 bar (85.72 psi)

Minimum Working Water Temperature

5° C (41° F)

Maximum Working Water Temperature

60° C (140° F)

Minimum Working Water Temperature

37° C (98° F)

Size of drainage pipe

φ 35mm (1.38")

MP3 compatible (Optional)